

PARSIFAL 500/500

Continuous through feed double disc grinder
equipped with a rotary table and 2 opposite vertical spindles

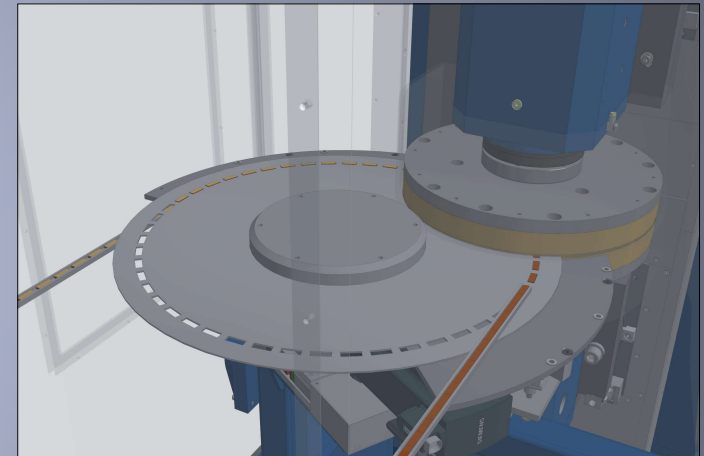
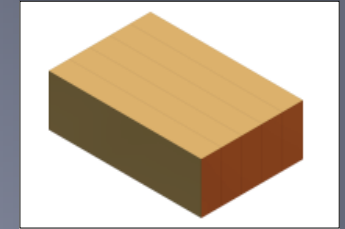
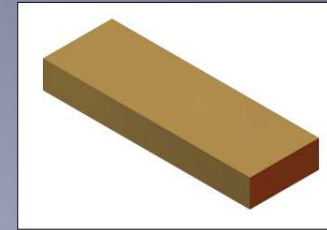
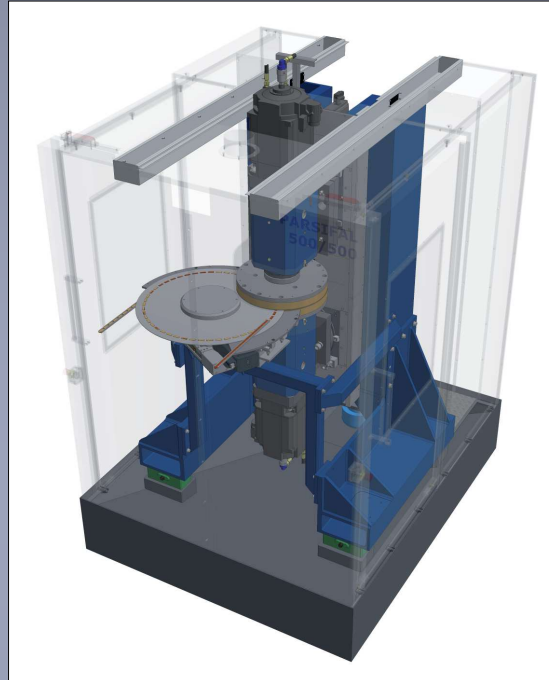

Performances

- Resolution 0.001 mm
- High performance spindles, direct drive
- Modular rigid frame of grey cast iron combined with prestressed concrete
- Measurement and automatic servo
- Additional brushing module

LINEAR ABRASIVE Engineering S.A.

Bellevue 5

2074 Marin / Schweiz

Tel.: +41 (0)32 753 36 33 Fax: +41 (0)32 753 21 69

E-Mail: commercial.center@linear.ch



LINEAR ABRASIVE

Technical specifications

Number of spindles	2	Abrasive tools	CBN/diamond/Al2O3
Spindle (mm)	2x ϕ 200x500	Grinding wheel (mm)	up to ϕ 500
Z-axis infeed (mm)	2x120	Infeed (mm/min)	0-4000
Direct spindle drive (rpm)	0-4500	Electrical control	Siemens S7/1500/TIA
Power (kW)	11/28/35	Total weight (t)	4.5
Width of machinable parts max. (mm)	5-60	Stock removal max. (mm)	up to 5
Height of machinable parts max. (mm)	1-20	Resolution (mm)	0.001

Technologie 2VV:

Continuous through feed surface grinder with 2 opposite vertical spindles

Combined operations

Highly productive method for continuous through feed machining of surfaces using Al2O3 cup, diamond and CBN wheels. The parts are transported by a disc pulling them between the two grinding wheels. Controlled process and part program provide optimum performance.

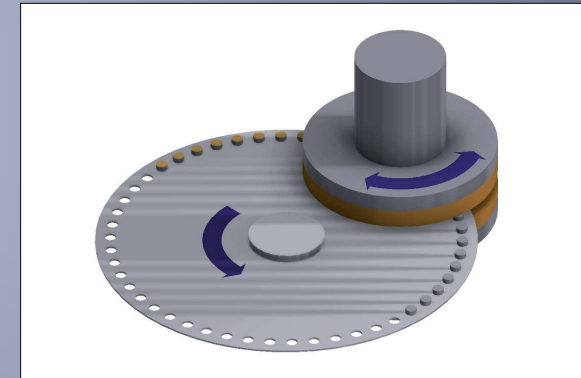

LINEAR ABRASIVE Engineering S.A.

Bellevue 5

2074 Marin / Schweiz

Tel.: +41 (0)32 753 36 33 Fax: +41 (0)32 753 21 69

E-Mail: commercial.center@linear.ch



LINEAR ABRASIVE