

STAG 140/400

Continuous through feed grinder, can be equipped with up to 3 vertical stations

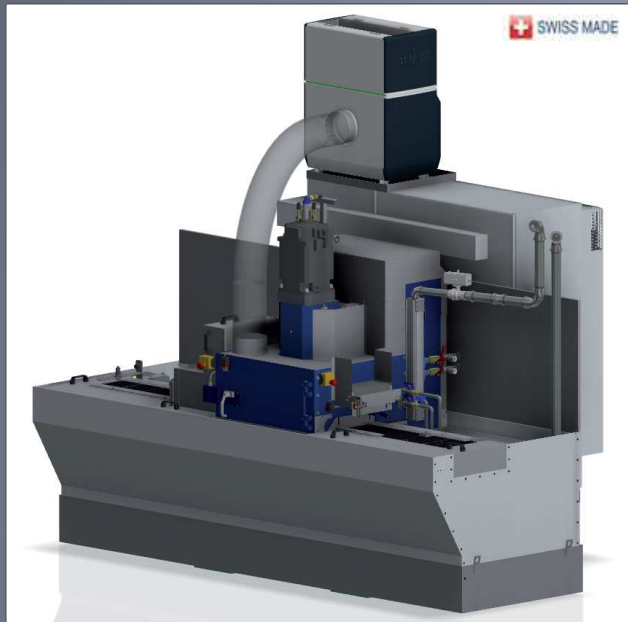

Grinding direction from right to left

Performances

- Resolution 0.005 mm or 0.001 mm (optional)
- High performance spindles, direct drive
- Modular rigid steel frame combined with prestressed concrete
- Measurement and automatic servo
- Additional brushing module
- Can be combined with up to 3 stations continuously
- Automatic, semi-automatic or manual loading

Spindle

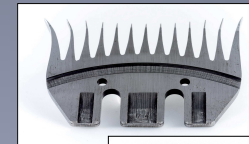
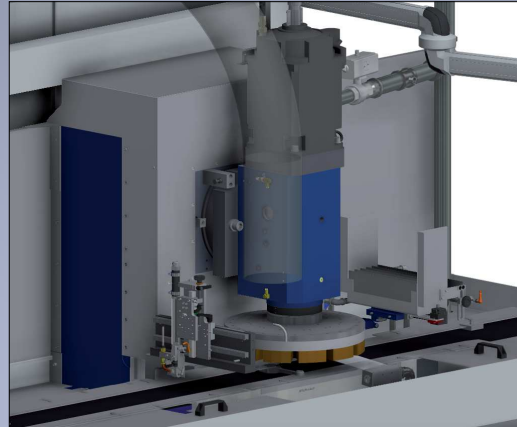

Measurement

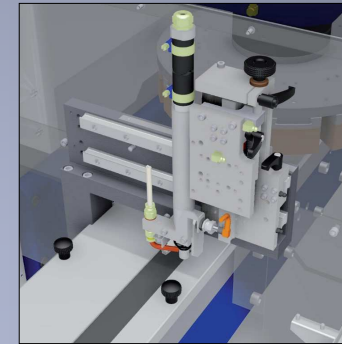

Manual

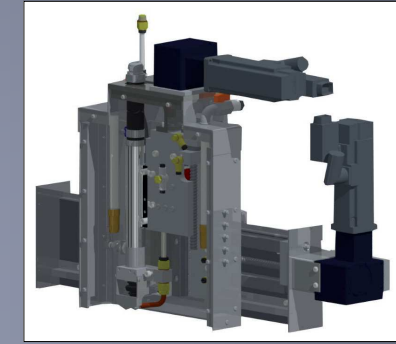

Automatic

Pumpingtank

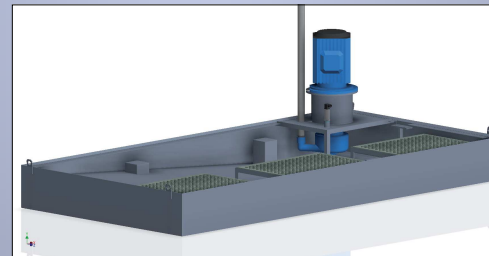

Brushing

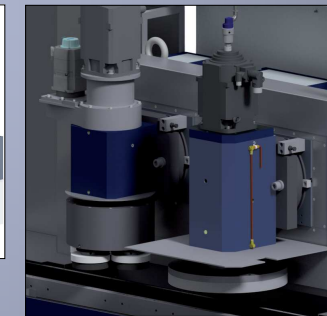

Dressing

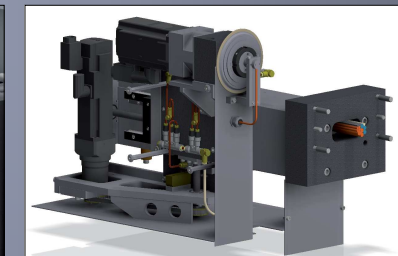

LINEAR ABRASIVE Engineering S.A.

Bellevue 5

2074 Marin / Schweiz

Tel.: +41 (0)32 753 36 33 Fax: +41 (0)32 753 21 69

E-Mail: commercial.center@linear.ch



LINEAR ABRASIVE

Technical specifications

Number of spindles	1 - 3 modular	Abrasive tools	CBN/diamond/Al2O3
Spindle (mm)	ø200x400 (+ optional brushing)	Grinding wheel (mm)	ø400
Z-axis infeed (mm)	120	Infeed (mm/min)	0 - 6000
Direct spindle drive (rpm)	0 - 4500	Electrical control	Siemens S7/1500/TIA
Power (kW)	7/11/2.5 (brushing unit)	Total weight (t)	3 - 7
Width of machinable parts max. (mm)	130	Stock removal max. (mm)	3
Height of machinable parts max. (mm)	100	Resolution (mm)	0.005 or 0.001 (optional)

Technology 1VB:

Continuous through feed flat surface grinder equipped with vertical spindle(s) + optional brushing unit(s)

Simple operation

Highly productive method for continuous through feed machining of surfaces, using corundum, diamond or CBN cup wheels. Transported by a highly resistant composite belt, held by magnetic attraction (by mask or template for parts of non-magnetic material) the parts are guided between rails and pass beneath the grinding wheel. Controlled process and part program provide optimum performance.

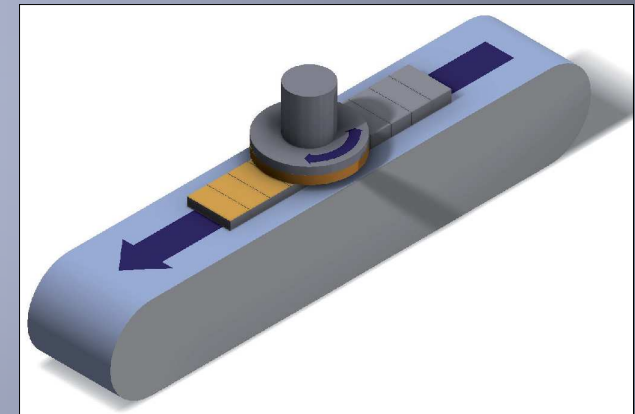

LINEAR ABRASIVE Engineering S.A.

Bellevue 5

2074 Marin / Schweiz

Tel.: +41 (0)32 753 36 33 Fax: +41 (0)32 753 21 69

E-Mail: commercial.center@linear.ch



LINEAR ABRASIVE